



HEART

Simulation and energy retrofits: tools for better decision-making

Energy performance

Fabrizio Leonforte, PhD
Presenting to 8th European Congress on the Use,
Management, Conservation of Buildings of Historical Value
Vienna, 16th October



TASK 59
RENOVATING HISTORIC BUILDINGS
TOWARDS ZERO ENERGY

2018 
ANNO EUROPEO
DEL PATRIMONIO
CULTURALE
#EuropeForCulture

Energy simulation of historical buildings: framework

The popularity of the energy simulation in historical buildings is due to many factors:



the amount of buildings considered as historical, which is equal to 30% of the total amount of the existing stock

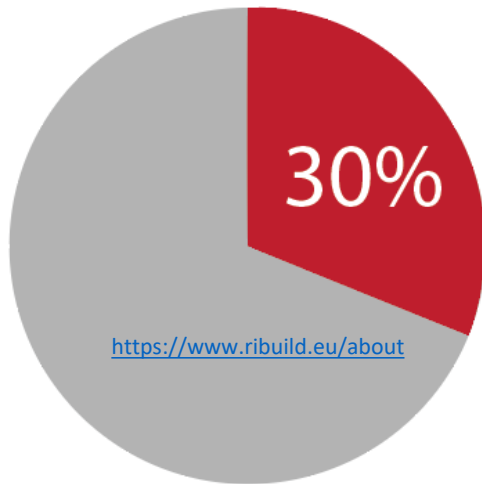

the need to balance energy efficiency improvement with the requirements of preservation, and

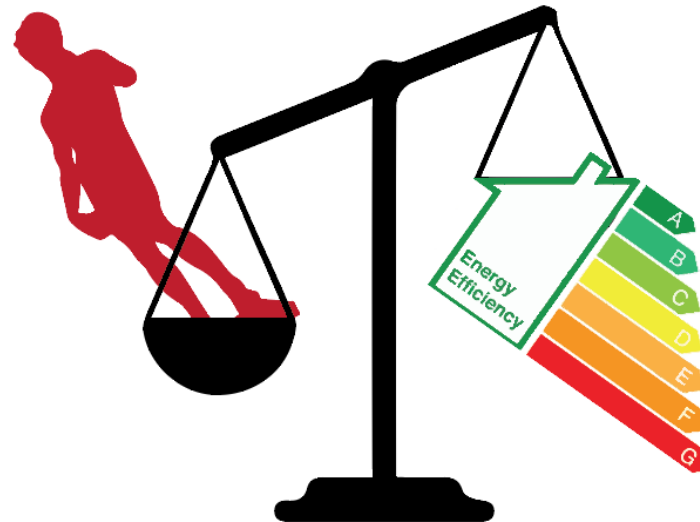

the scarce knowledge about their thermal behaviour.



Energy simulation of historical buildings: aims

Dynamic simulation tools must be used in the field of historical buildings in order to:

- (i) analyse the possible degradation risks to materials, determined by specific environmental temperature and relative humidity ranges;
- (ii) to identify some misuse or failure during the operation phase
- (iii) assess multiple energy retrofit scenarios.



Cracks



Efflorescence



Corrosions

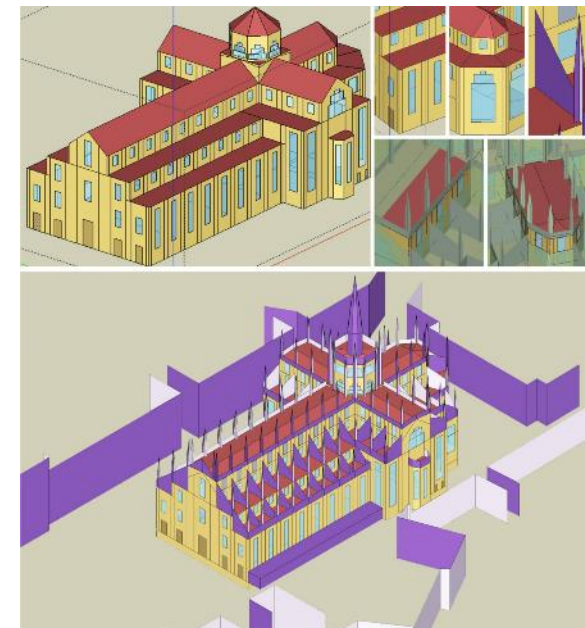

Energy simulation of historical buildings: Limitations

1. Designers are not able to identify the best optimal solution among different alternatives
2. The simulation results are not reliable



A simulation that are not reliable are useless!

Energy simulation reliability

In such respect, bridging the gap between predicted and measured performance is pivotal in order to **provide serious and reliable advice to designers, architects, buildings' owners and policy makers, on the real performances of the buildings.**

This will **increase the awareness amongst clients and design teams** on the energy behaviour and performances of the building, estimating the effectiveness of different energy efficient solutions and ensuring the achievement of the forecasted energy performance.

Moreover, such information can be adopted **to plan and to schedule effective interventions and maintenance programs** as well as **to reduce the risk for owners and investors** (i.e. damage, structural problems, and so on). The enforcement of energy performance guarantee, in fact, allow **the decreasing of the uncertainty** about the final outcome. This latter factor can offer a significant contribution to the development of new rules and strategies for real estate and energy finance, innovating the traditional conservative approaches (i.e. restoration or planned conservation).

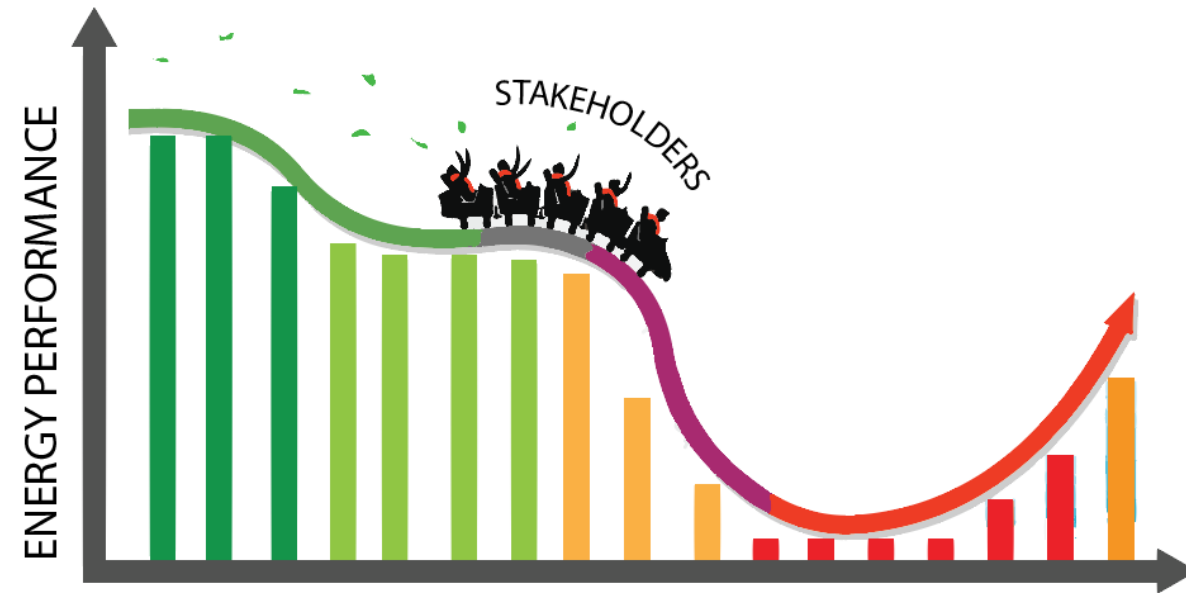

HEART Project General information

- **OFFICIAL TITLE:** HEART - Holistic Energy and Architectural Retrofit Toolkit
- **RELEVANT KEYWORDS:** Renovation, Energy efficient buildings, Internet of Things, Interoperability, Integrated design
- **DURATION:** 48 months (01/10/2017 – 30/09/2021)
- **EU CONTRIBUTION:** 5,669,012.50 €
- **PROJECT COORDINATOR:** prof. Niccolò Aste, Politecnico Di Milano, niccolo.aste@polimi.it
- **WEBSITE:** www.heartproject.eu
- **LINKEDIN:** www.linkedin.com/groups/8642064/profile
- **TWITTER:** twitter.com/HEARTProjectEU

GOAL: to develop a toolkit for the energy retrofit of residential building, in combination with DSS and BEMS able to provide a reliable forecast of the energy performance



This project has received funding from the European Union's Horizon 2020 Research and Innovation Programme under grant agreement N° 768921.



Objectives

OBJECTIVE – To support and improve the **decision-making process**

By means of an iterative simulation of various feasible solutions, **HEART selects and sizes the most effective one**, providing a detailed prediction of the achievable cost-performance-benefit ratio.

In addition to strengthening the economic and energy-related benefits **HEART can support and facilitate decision-making**, reducing the choices' processing time by at least 30% and decreasing final outcome uncertainty of the decision-making phase.

OBJECTIVE – To promote **energy efficient financing**

HEART reduces energy consumption, optimizes overall performance and, through a continuous monitoring and makes a building's operating transparent. This aspect translates into an effective conduct of a retrofit intervention and a constant documentation of its performance.

HEART will develop innovative business models to support energy efficiency financing, oriented both at private investments and at public incentives. It can be estimated that these tools, **breaking down risks and uncertainties, will increase by 20% the attractiveness of energy retrofit investments.**

Consortium

N°	PARTICIPANT ORGANISATION NAME	SHORT NAME	COUNTRY
1	Politecnico di Milano	POLIMI	Italy
2	ENTPE Lyon	ENTPE	France
3	University of Ljubljana	UL	Slovenia
4	Accademia Europea di Bolzano	EURAC	Italy
5	Turbo Power Systems	TPS	UK
6	Heliotherm	HT	Austria
7	ZH	ZH	Italy
8	VyzVoice	VV	Luxembourg
9	STILLE	ST	Croatia
10	Revolve Water	RW	Belgium
11	Quantis	QT	Swiss
12	GarciaRama	GR	Spain
13	Housing Europe	HE	Belgium
14	ACER RE	ACER	Italy
15	Est Métropole Habitat	EMH	France
16	CTIC Technology Centre	CTIC	Spain



University of Ljubljana
Faculty of Mechanical Engineering



Application context and target

The project's geographical focus is **Central and Southern Europe**, where the moderate climate requires building energy performance to relate as much as to **heating, overheating and cooling**.

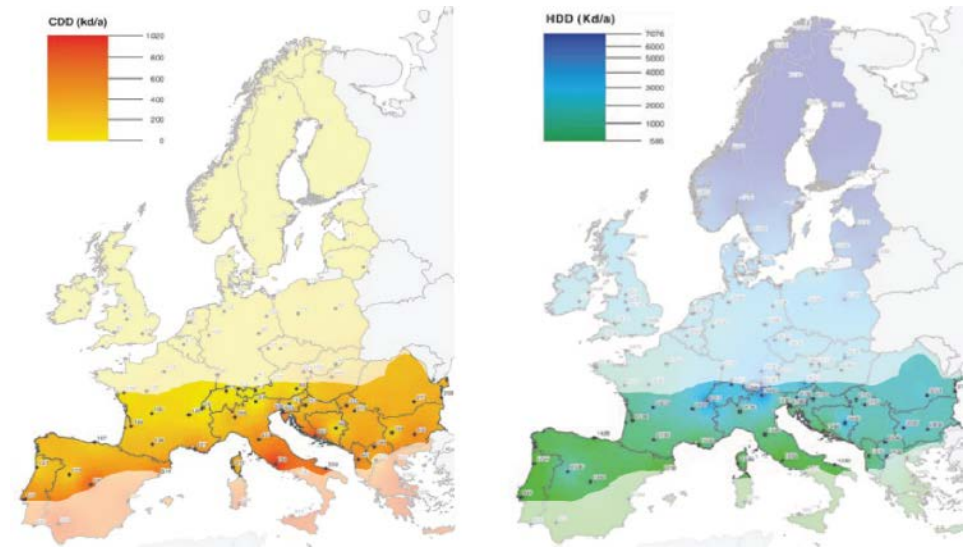

The application target are existing **multi-storey residential buildings**. Within this category, the most common types are **4-5 floors linear condominium buildings**.



HEART Toolkit

- 1) Retrofit components/techniques for existing windows;
- 2) Multifunctional external thermal insulation;
- 3) Universal PV tiles;
- 4) Cloud-platform;
- 5) DC Smart fan coils;
- 6) Thermal storage;
- 7) Battery pack;
- 8) DC heat pump;
- 9) Multi-Input/Multi-Output converter (MIMO);

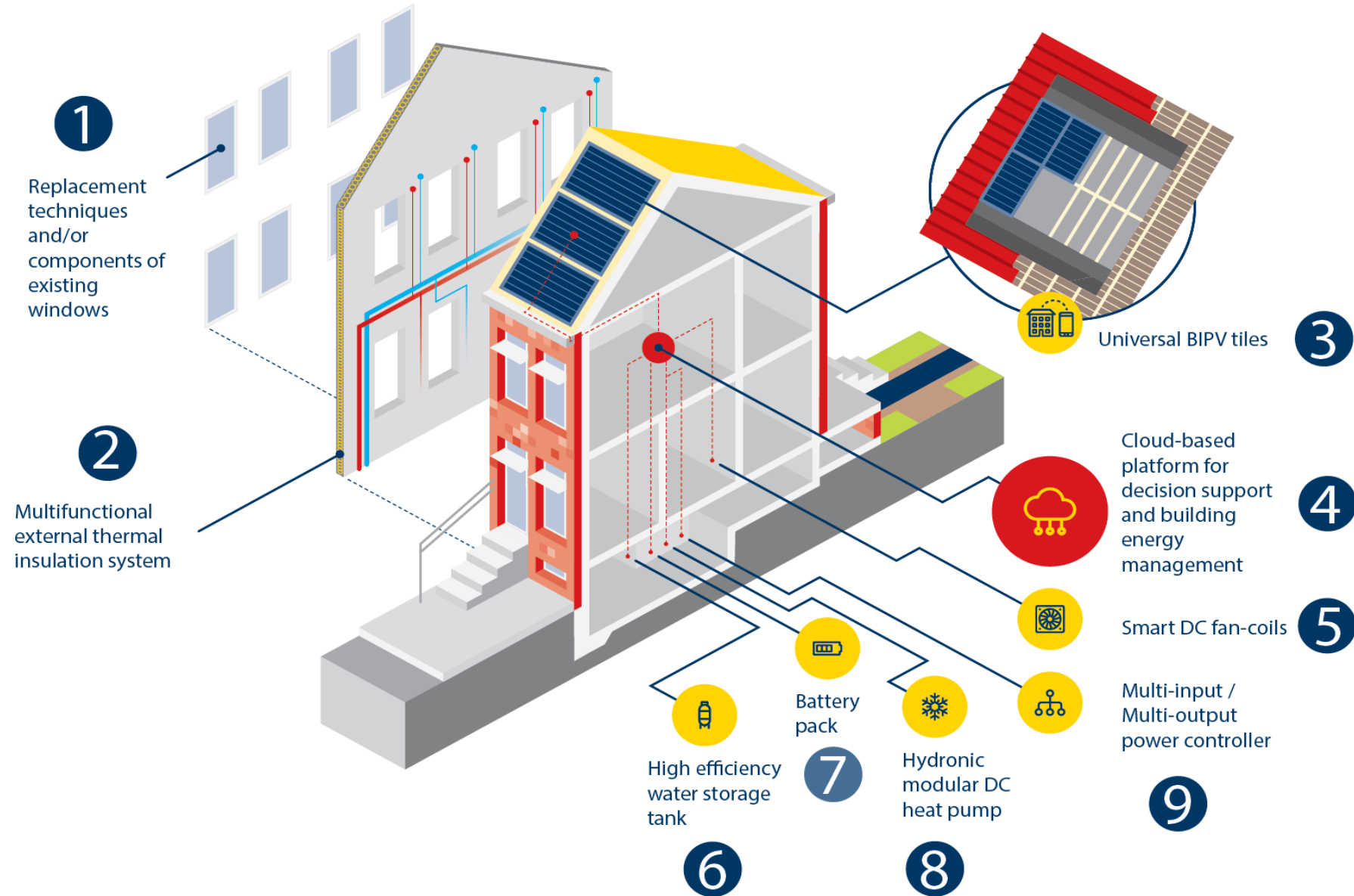

HEART subcomponent - non intrusive component

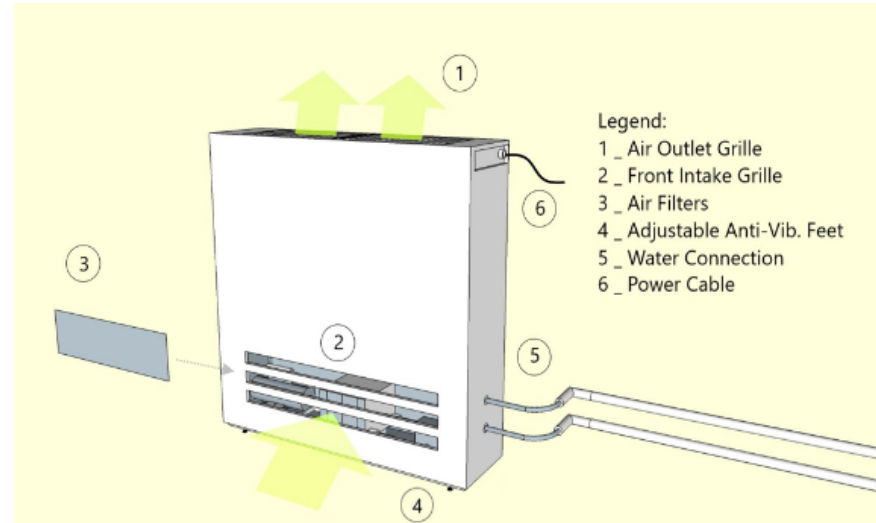
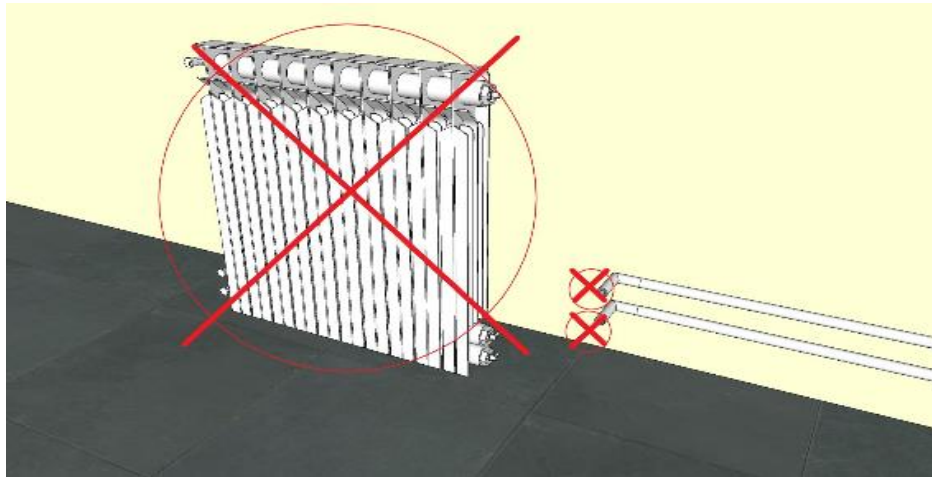

Smart fan-coil

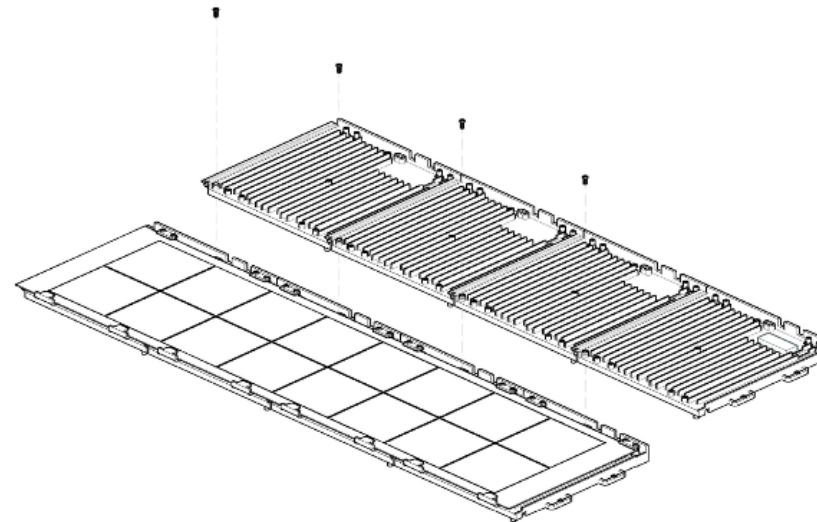
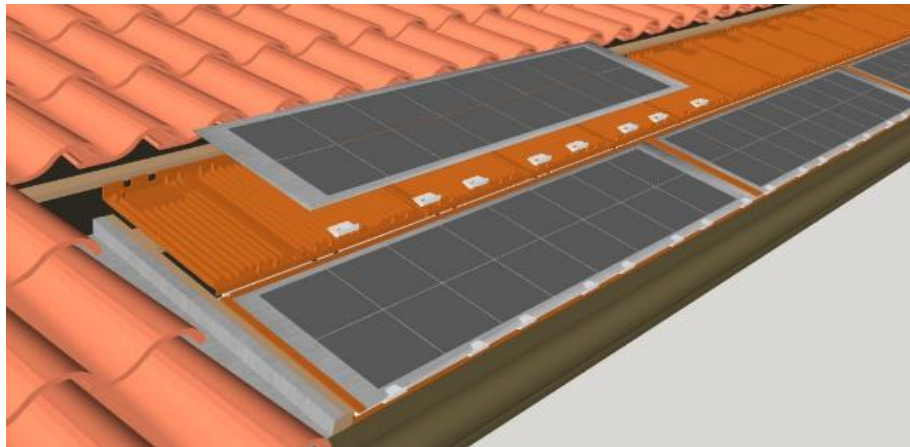

PV Tiles

The decision-making phase

The HEART cloud platform allows the decision maker (designer, building owner, investor) to find the **optimal configuration** under the technical-economic point of view

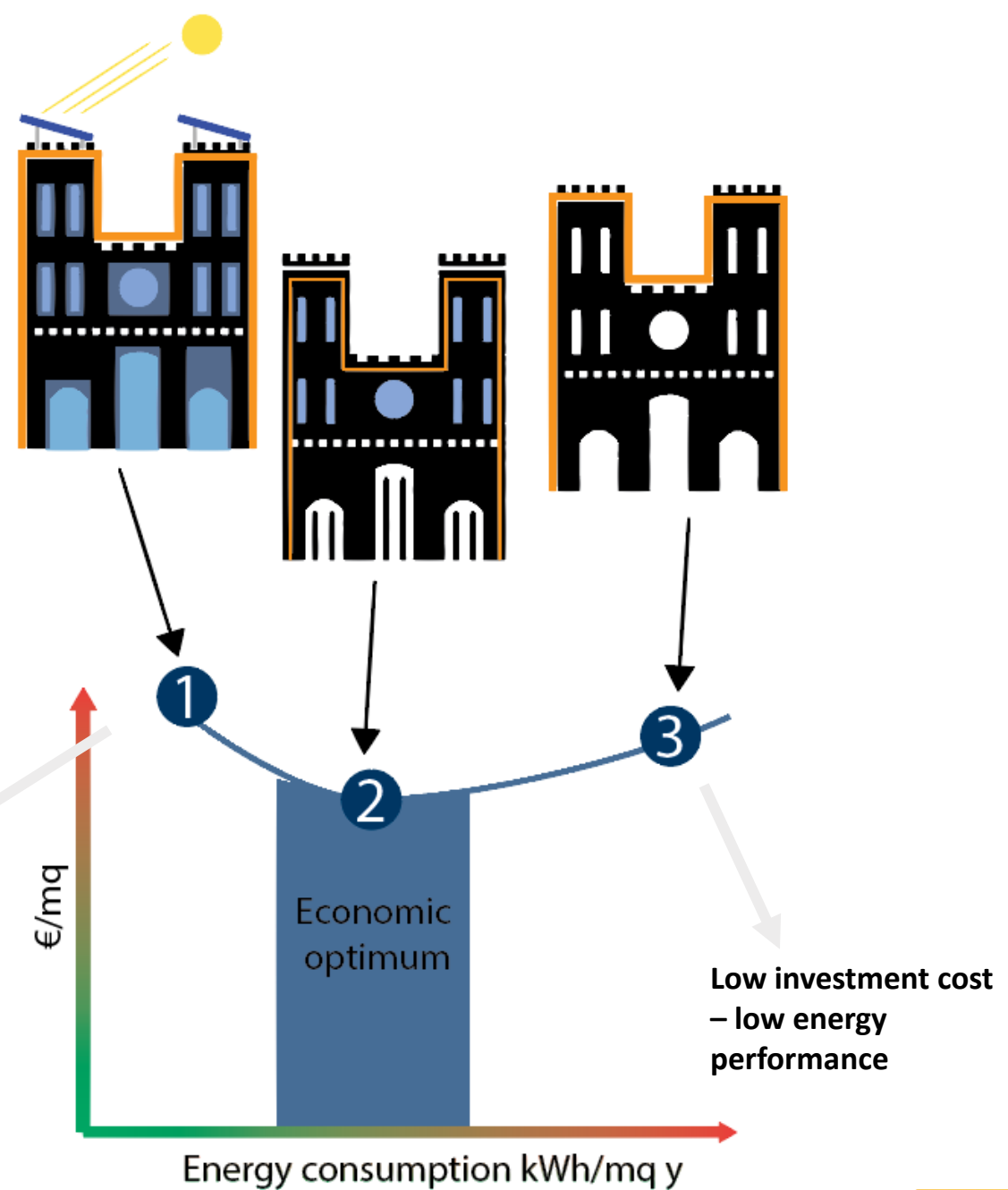

HEART Cloud-Based Structure

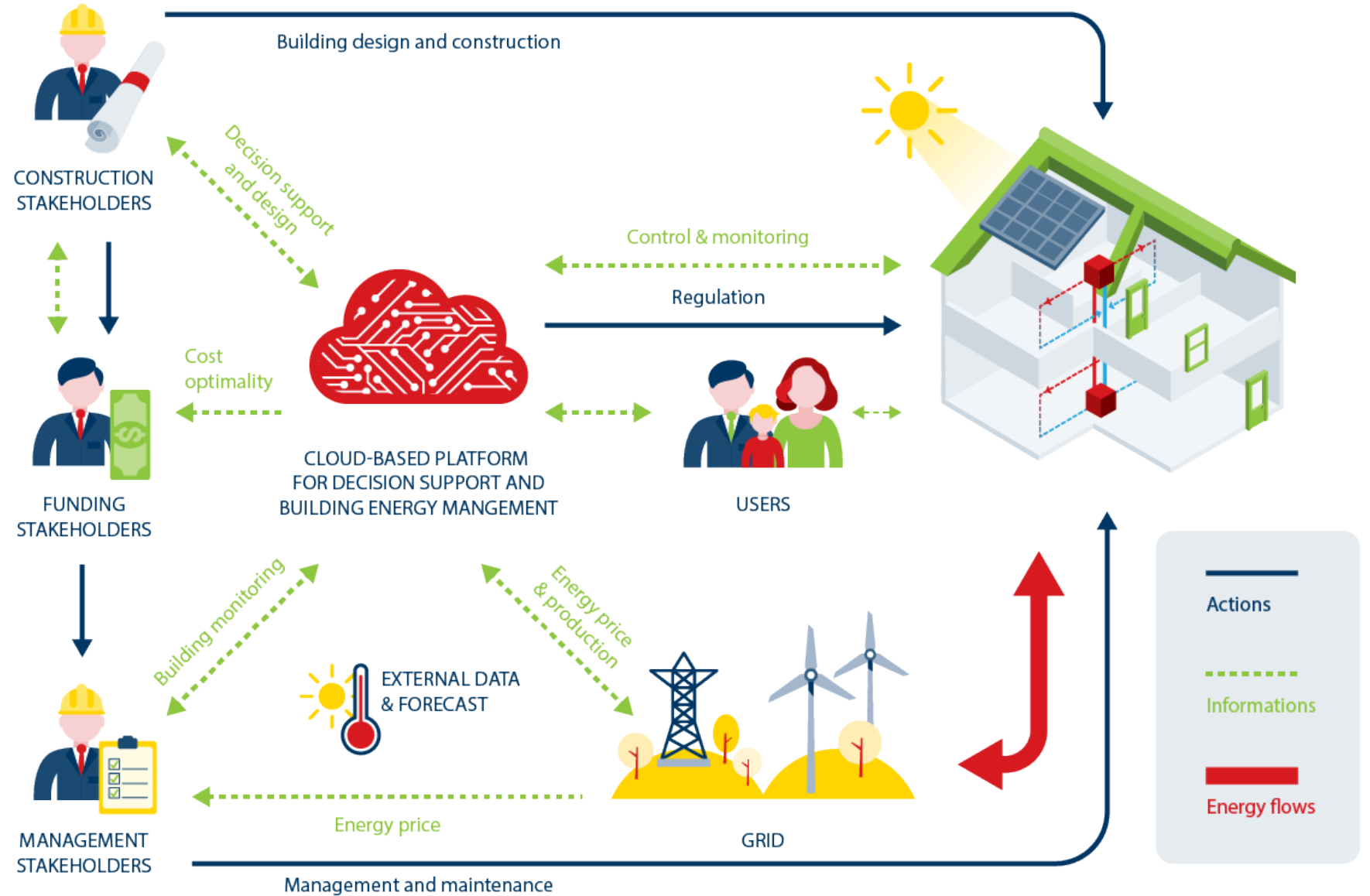

Using external (weather forecast, variation in energy tariffs) and internal (inputs and feedbacks from building's users) information, the web platform lowers the building's energy consumption and optimizes grid interactions. The platform defines the HEART toolkit operations, by applying a predictive-adaptive logic to guide the building system's efficiency.

The operational phase

The HEART cloud platform acts as an **adaptive-predictive energy management tool**.

It also allows those who manage the building (energy manager, owner etc.), but also the O&M service and the investor, to **monitor the technical and economic performance** and to detect any anomalies in real-time.

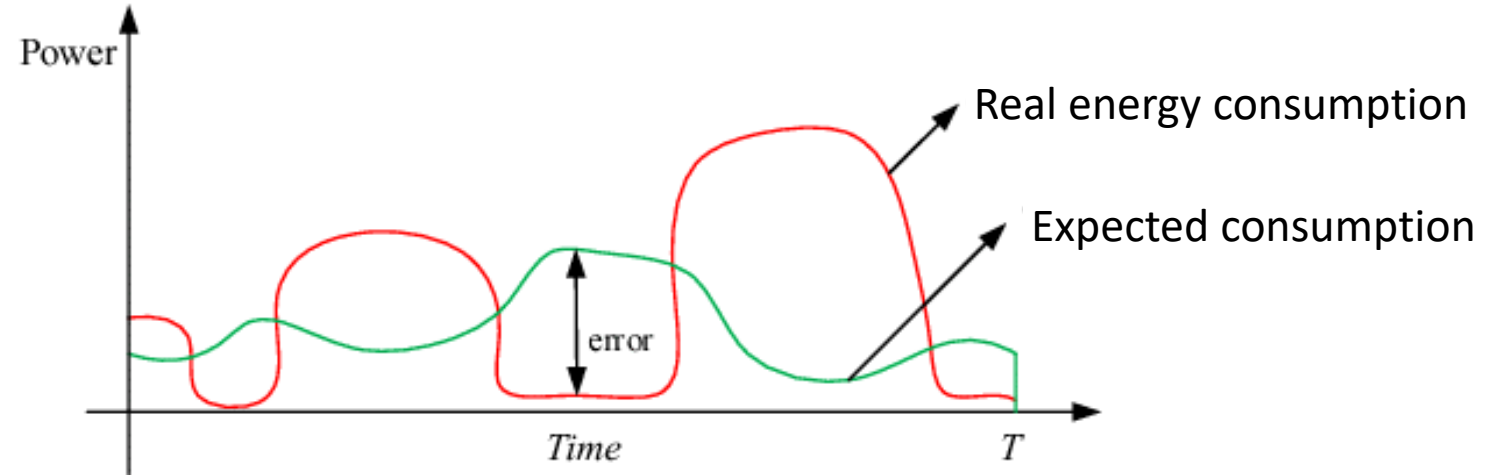

Immediate detection of faults or anomalies

The cloud based platform, can support and facilitate the decision making, reducing the choices' processing time by at least 30% and decrease the final outcome uncertainty to a margin of +/- 5%

Conclusion

The advanced data analytics of the simulation is used to:

- enhance and fact-check **awareness of renovation cost-effectiveness**: **high and reliable energy and economic performances are guaranteed in decision-making** by the fact the Toolkit is based on robust/cost-effective technical solutions coupled with advanced energy model/optimization logic to ensure the selection of the best retrofit strategy.
- **Increase the level of confidence and reduce the investment risk**: the energy and economic performance in the operational phase is ensured by an accurate BEMS and by several reporting strategies to keep the various stakeholders aware about the behaviour of the building, preventing wrong habits and allowing timely and effective interventions and maintenance programs. The mismatch between the expected and the actual performances will be kept below 5%.

Energy retrofit of existing buildings, when properly managed, represents an interesting form of investment and is attractive for funding. However, unlike other forms of energy finance, results and **payback times are foggy because of the uncertainty margins related to building projects and management**. These barriers can be removed by introducing **appropriate tools** for planning, **forecasting and control of energy performance that safeguard the investments**.

In HEART, suitable ICT tools developed within the cloud-based platform **enforce energy performance guarantees, provide proper information and assure greater certainty for investors**. This latter factor can offer a significant contribution to the development of new rules and strategies for real estate and energy finance, innovating traditional conservative

Thanks for your attention

Scan the QR code to sign up
to our email newsletter:



www.iea-shc.org



SOLAR HEATING & COOLING PROGRAMME
INTERNATIONAL ENERGY AGENCY



<http://task59.iea-shc.org/>



task59@eurac.edu



[HistoricNZEB](#)



[HistoricNZEB](#)



[@HistoricNZEB](#)

You can sign up to
our seasonal
newsletters here:
[http://eepurl.com/gl
yfBr](http://eepurl.com/gl
yfBr)



www.heartproject.eu



HEARTProjectEU



HEARTProjectEU